

# CATALOGUE

in US Customary Unit System

# BULWAGGA ANCHOR

When you really need to be sure!



# BULWAGGA ANCHOR

## ABOUT BULWAGGA



Bulwagga is the new word in the world of anchors. The concept behind the Bulwagga is fairly straightforward. Its three large flukes are designed to ensure that two flukes will always be properly aligned to dig into the bottom no matter how the anchor is oriented. The shank can pivot in the center of the anchor to help keep the load on the two working flukes equalized.

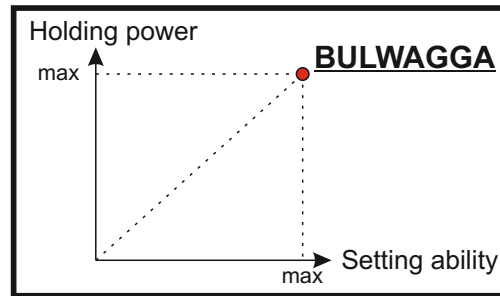

## WHY BULWAGGA

TECHNICAL SPECS	DIFFERENCE with OTHERS	WHAT YOU GET
120° angle between flukes	Unlike the usual plow type anchors, Bulwagga Anchor lands onto the bottom always in right position ready to immediately pierce and plunge the seabed.	No drag till holding. The anchor holds closer to the location of drop.
Centrally symmetrical three flukes Unique 30° angle of flukes to the seabed	The side pulls are inconvenient for usual anchors to begin piercing the sea bed as they need first to position their flat flukes horizontal to seabed. However Bulwagga Anchor flukes, thanks to their unique 30° angle to the seabed, the side pulls by contrast scratches the bottom easing them to begin digging.	Sooner holding with less chain slack. Better holding despite the snake movement of the boat in windy and gusty conditions.  Holding with less slack makes easier your anchorage in crowded bays and harbours.
Distantly designed flukes	Releases weed behind in between flukes, enabling the Bulwagga Anchor to reach and dig the bottom. In heavy weedy bottoms other type of anchors are simply useless as the weed stuck between their shaft and fluke preventing them to plunge into the seabed. This unique feature of Bulwagga Anchor makes it matchless compared to any other anchor design.	Less concern in determining the suitable location for anchorage, especially at night when it's hard to distinguish the weedy and sandy areas.

# BULWAGGA ANCHOR

## ABOUT BULWAGGA

TECHNICAL SPECS	DIFFERENCE with OTHERS	WHAT YOU GET
Free rotating shaft	No need to use swivel for chain-shaft connection, which is always an issue to worry about resistance.	Avoids using extra high cost element and simplifies the connection of the anchor to the chain. Avoids resistance worries about the swivel and its connection elements related to the swivel, namely from the chain to swivel and from the swivel to the anchor.
Free forth and back moving shaft	The Bulwagga Anchor's shaft is free to get retracted towards to opposite of its plunge direction and this unique feature avoids any concern that the anchor could be squeezed or trapped in rocky bottoms.	Less concern in the choice of anchorage location. Less trouble in rocky bottoms. Easy to retract.
The Bulwagga Anchor is made by welding plasma cut plate metal, unlike the usual cast metal anchors.	More flexible and much stronger than any other anchor compared to its weight.	Less weight on the bow of your boat
Plasma cut flukes from steel plate	Sharper edges, well pointed tips.	Cuts weed and sooner digging, less dragging in hard bottoms.



Plasma cut parts

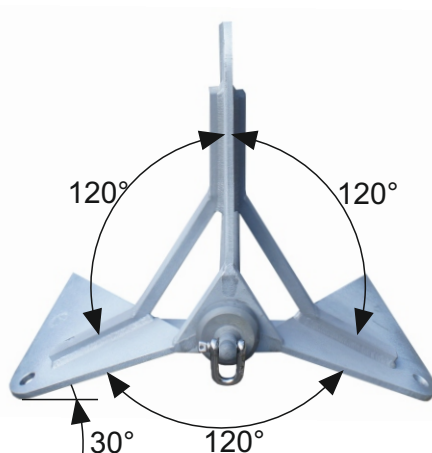

Symmetrical three flukes



Free forth and back moving shaft

# BULWAGGA ANCHOR

## ANCHOR TYPES

### Hot dip galvanized type.

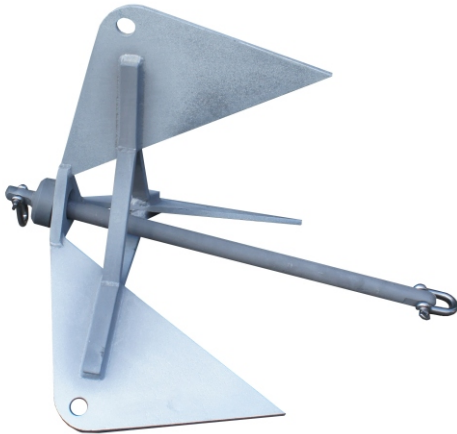

### Stainless steel types:



- made of 316L stainless steel
- made of 316Ti stainless steel

## HOW TO CHOOSE THE RIGHT SIZE

Boat Length (ft)	Boat Displacement (lbs)	Anchor size and weight (lbs)	Recommended Chain Size (inch)
Up to 20	Up to 1 100	Size 1 - 14.2	1/4
20-30	1 100-4 400	Size 2 - 22.6	5/16
30-40	4 400-13 500	Size 3 - 34.7	5/16
40-50	13 500-20 000	Size 4 - 51.1	3/8
Up to 60	20 000-26 500	Size 5 - 84.2	1/2

Shackles types which are fitting to Bulwagga Anchor are listed below those shackles can be used as a reference;

- Crosby G-213 / S-213 Round Pin Anchor Shackles
- Crosby G-209 / S-209 / G-210 / S-210 Screw Pin Anchor Shackles
- Crosby G-2130 / S-2130 Bolt Type Anchor Shackles

# BULWAGGA ANCHOR

## PRODUCTION & QUALITY

We manufacture Bulwagga anchors in the best quality to make you feel safe in any type of unpredictable conditions. Here below you can see our manufacturing process step by step.

**1.** Crown, flukes, supports and crown are cut from steel plate. In shaft and nut threads are made for better holding (galvanized and stainless steel).

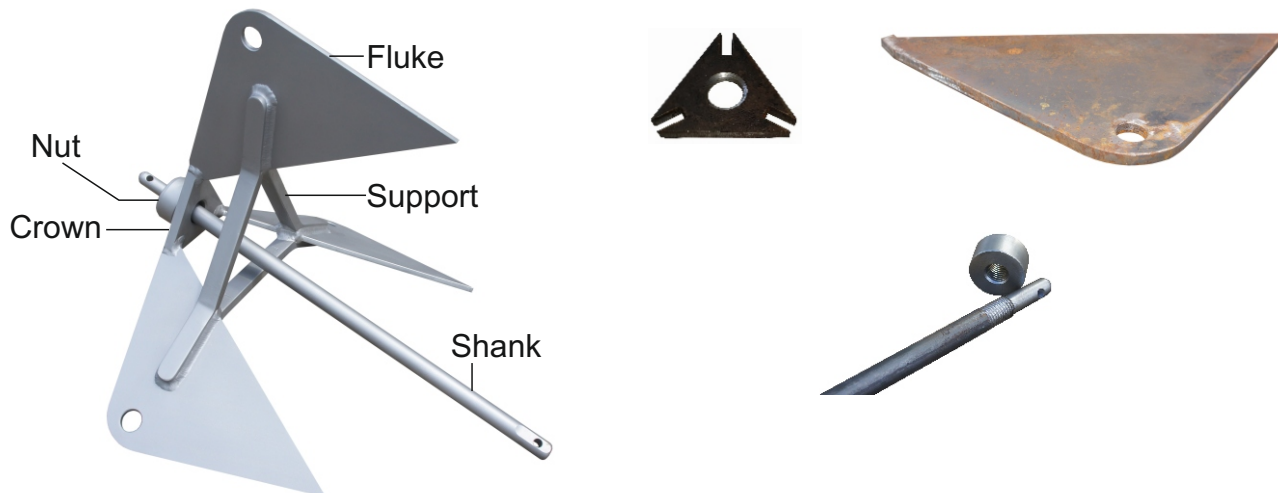

**2.** Parts undergo sandblasting. Through this process all the impurities on the surface are eliminated to ensure perfect welding quality (galvanized and stainless steel).



**3.** Products are ready to be welded. Welding is done by certified welders (manual welding). Welding type: TIG (tungsten inert gas) with pure Argon gas (galvanized and stainless steel).



**4.** Welded anchors are given for sandblasting again. In galvanized model it makes galvanize coat the surface evenly and stronger. In stainless steel model it makes surface smooth and good looking.



# BULWAGGA ANCHOR

## PRODUCTION & QUALITY

5. At last anchors are hot dip galvanized. Minimum galvanize thickness - 70 micron.



**For your attention:** In galvanized products you can see spots on crown (as you can see in the last photo). These are places where welding was done. In the first photo flukes are replaced into crown and welded. After that, the product is grinded and given for sandblasting. As you may see in the second photo, there is no difference between steel and welded area. Finally, products are galvanized. At this point some spots may appear on the surface of the anchor. This is unavoidable because different types of materials hold galvanize in different ways. Spots on and under crown can tell you about the welded area and also the strength of the anchor. You can see that every single inch is perfectly welded. **You can have full trust for your BULWAGGA!**



Stainless steel finished product:



Additionally you can ask for third party inspection and obtain quality certificates for the Bulwagga anchors you buy.



# BULWAGGA ANCHOR

## ANCHOR DIMENSIONS

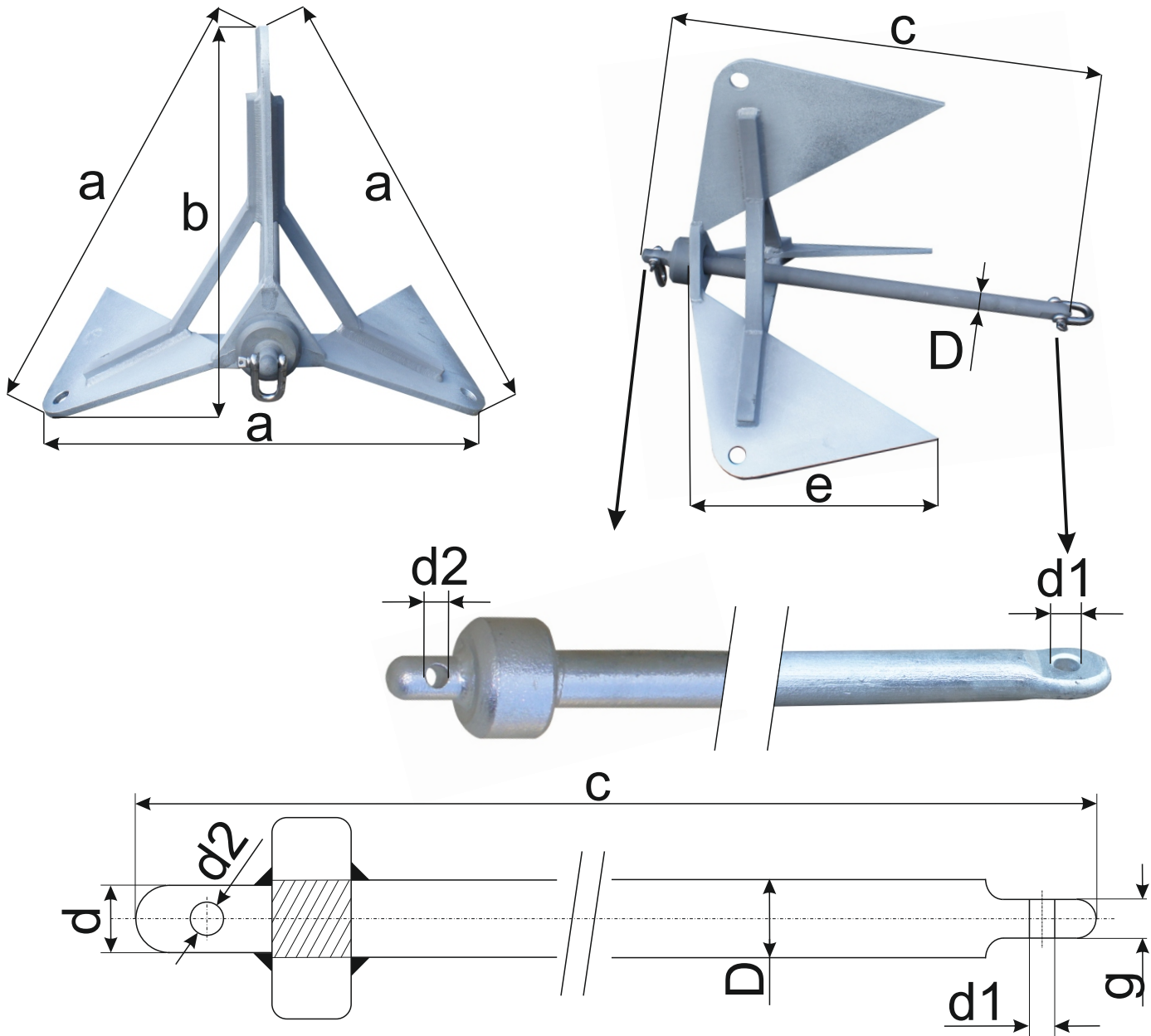

Anchor Size	a, inch	b, inch	c, inch	D, inch	d1, inch	d2, inch	e, inch	d, inch	g, inch
Size 1 - 14.2 lbs	15.4	13.4	18.1	0.63	0.394	0.275	10.2	0.43	0.394
Size 2 - 22.6 lbs	18.5	16.1	21.9	0.87	0.453	0.354	12.2	0.59	0.433
Size 3 - 34.7 lbs	21.7	18.9	25.4	0.945	0.453	0.433	14.2	0.75	0.433
Size 4 - 51.1 lbs	24.4	21.3	28.74	1.1	0.531	0.531	16.1	0.87	0.57
Size 5 - 84.2 lbs	28	24.4	32.7	1.38	0.708	0.531	18.1	1.1	0.708

# BULWAGGA ANCHOR

## PACKAGING & WEIGHTS



Packaging



Labeling

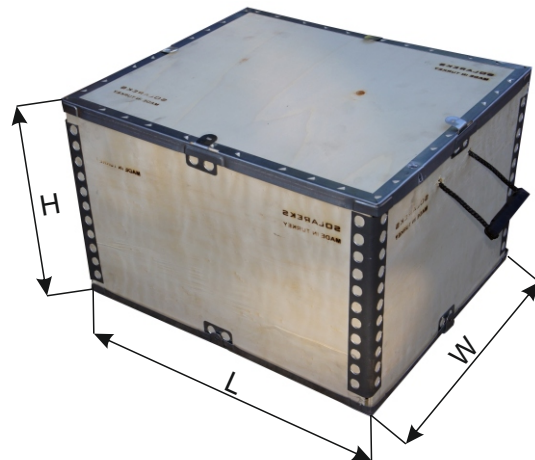

Dimensions

Anchor Size	H, inch	L, inch	W, inch	Package weight, lbs
Size 1 - 14.2 lbs	11.42	16.93	14.76	20.26
Size 2 - 22.6 lbs	13.19	19.69	17.32	30.97
Size 3 - 34.7 lbs	15.55	22.64	20	46.67
Size 4 - 51.1 lbs	17.32	25.98	22.76	65.59
Size 5 - 84.2 lbs	19.49	29.53	25.59	101.02

## CONTACTS

### SOLAREKS SOLAR ENERGY SYSTEMS

Factory Address: İmes Sanayi Sitesi A Blok, 106. Sokak No: 48 Yukari Dudullu – Istanbul/ TURKEY  
Postal Code: 34776

Phone: +90 216 314 85 80

[info@solareks.com](mailto:info@solareks.com)

Fax: +90 216 364 10 29

For English: +90 532 685 96 30

USA Sales: Dr. Aysegul Gunduz (Ms.)

Phone: +1 407 761 55 99, Email: [aysegulgunduz97@gmail.com](mailto:aysegulgunduz97@gmail.com) / [aysegul@solareks.com](mailto:aysegul@solareks.com)

International sales & Technical support: Mr. Engin Kurtay

Phone: +90 542 213 39 47, WhatsApp: +90 545 942 01 54, Email: [engin\\_kurtay@yahoo.com](mailto:engin_kurtay@yahoo.com)

[www.bulwaggaanchor.com](http://www.bulwaggaanchor.com)

[www.solareks.com.tr](http://www.solareks.com.tr)

[www.marine-boiler.com](http://www.marine-boiler.com)

[www.solarekstermosifon.com](http://www.solarekstermosifon.com)

[www.solareksboiler.com](http://www.solareksboiler.com)

All Rights Reserved. No part of this technical catalog may be reproduced, stored in a retrieval system, or transmitted, in any form or by any means, electronic, mechanical, photocopying, recording or otherwise, without the prior permission of the Copyright owner. For information regarding permission, write to: [info@solareks.com](mailto:info@solareks.com)